



POP[®]

ProSet[®] 3400 Rivet Tool

Lightweight Tool with Heavyweight Force

Features & Benefits:

- **Ergonomic**

- Lightweight, strong polymer construction
- Comfortable two finger, low activation force trigger
- Directionable air exhaust (MCS model)
- On/Off, left or right swivel air fitting

- **Performance / Economy**

- High force-to-weight ratio
- Quick disconnect nose housing
- Quick disconnect jaw case
- Quick disconnect Mandrel Collection System
- Spring return for a reliable fast setting cycle

- **Adaptability**

- POP[®] Rivet Presenter (RP) compatibility
- POP[®] Remote Mandrel Collection System (MCS5000)
- POP[®] Specialty Heads

- **Safety**

- Air-isolation switch during MCS removal

The lightweight ProSet[®] 3400 Rivet Tool is the heavyweight of the ProSet[®] family. The high capacity 3400 delivers the highest pulling force in its class but weighs in at just over 4 lbs.

Built with ergonomics in mind, this tool features the patented Quick Disconnect nose housing and jaw case for rapid maintenance of the front end – with no need for tools! The Quick Disconnect Mandrel Collection System (MCS) safely collects spent mandrels for easy disposal and cleaner work areas. The air isolation switch on the MCS eliminates air flow when the MCS is disconnected. A rugged aluminum casting is designed to prevent damage and enhances the life of the tool.

The left-right 90° swivel air fitting ensures the tool can be adapted to any workstation and the "on/off" switch minimizes air consumption and noise. A spring return ensures fast, consistent and reliable setting cycles reducing operating costs. The ProSet[®] 3400 is compatible with the POP[®] Rivet Presenter, the POP[®] Remote MCS System (MCS5000) and POP[®] specialty heads.

The 3400 will set 1/8" (3.2mm), 5/32" (4.0mm), 3/16" (4.8mm) and 1/4" (6.4mm) diameter rivets in all materials including stainless steel high strength structural rivets.

Quick Disconnect Mandrel Collector



Quick Disconnect Nosehousing



Quick Disconnect Jaw Guide Technology



www.BylerRivet.com

**Emhart[®]
Teknologies**
POP[®]

POP[®]

ProSet[®] 3400 Rivet Tool

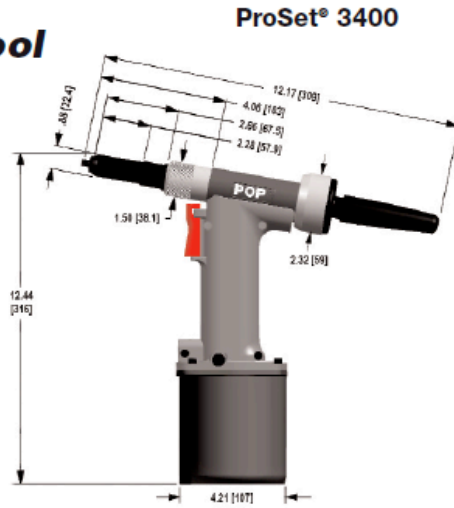

ProSet[®] 3400

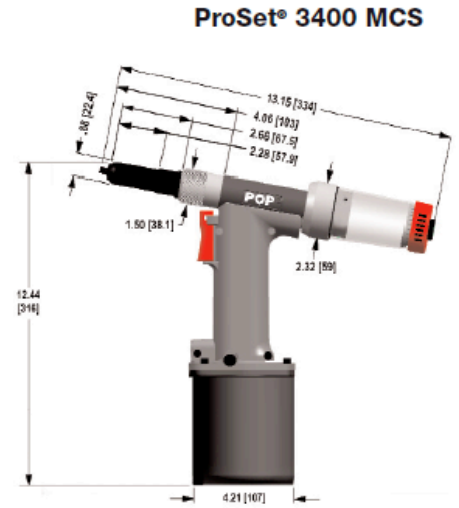

ProSet[®] 3400 MCS

Specifications

Model Number	ProSet [®] 3400	ProSet [®] 3400MCS
Weight	4.19 lbs. (1.90 kg)	4.41 lbs. (2.00 kg)
Length	12.17" (309 mm)	13.15" (334 mm)
Height	12.44" (316 mm)	
Tool stroke	1.02" (26 mm)	
Pulling force	4,160 lbs @ 90 psi (18,500 N @ 6.2 bar)	
Force/Weight ratio	993 lbf/lb (9.7 kN/kg)	943 lbf/lb (9.2 kN/kg)
Air consumption	0.172 cu. ft/rivet (4.86 liters/rivet)	2.83 scfm (max) [80 liters/min (max)]

Optional Accessories

Part Number	Description
FA203-408	MCS5000 Adaptor kit for 4, 5, 6 size rivets
FA203-414	MCS5000 Adaptor Kit for 8 Size Rivets
FAN276-075	ProSet [®] 3400 8" Front End Extension kit
FAN276-152	ProSet [®] 3400 Seal kit
FAN276-165	Mandrel Collection System Retrofit kit
PRH840-3400	PRH840 Corner Head Adaptor
PRH850-3400	PRH850 Corner Head Adaptor
RP4-501	RP4/ RP5 Receptacle
RP6-501	RP6 Receptacle

Rivet Capacity

Rivet Type	Material (Body-Mandrel)	Rivet Diameter			
		1/8" ^(*) (3.2 mm)	5/32" ^(*) (4.0 mm)	3/16" ^(**) (4.8 mm)	1/4" ^(†) (6.4 mm)
Open End & Multi-Grip [™]	Al – Al	✓	✓	✓	✓
	Al – St / SS	✓	✓	✓	✓
	St – St	✓	✓	✓	✓
	SS – SS; Mo – St / SS	✓	✓	✓	✓
Closed End	Al – Al	✓	✓	✓	✓
	Al – St / SS; Cu – St	✓	✓	✓	✓
	St – St	✓	✓	✓	✓
	SS – SS	✓	✓	✓	✓
LSR Rivets	Al – Al	✓	✓	✓ ^(†)	NA
T Rivet	Al – St	✓	✓	✓ ^(†)	✓
Self Plugger	St – St	✓	✓	✓ ^(†)	✓
HR [™] Rivets	St – St	✓	✓	✓ ^(†)	X
HS Rivets	Al – Al; St – St	NA	NA	NA	✓
Ultra-Grip [®]	Al – Al; St – St; SS – SS	NA	NA	✓ ^(†)	✓



Corner Head

MCS Retrofit Kit



Byler Rivet Supply 2118 Parkside Ave. Irving, Texas 75061 (972) 986-6792 Fax (972) 986-2832

www.BylerRivet.com and www.poprivettooling.com